

YMS COOLING TOWERS

Counter flow, Bottle type ,FRP Cooling Towers

*Cooling towers designed for
your needs*

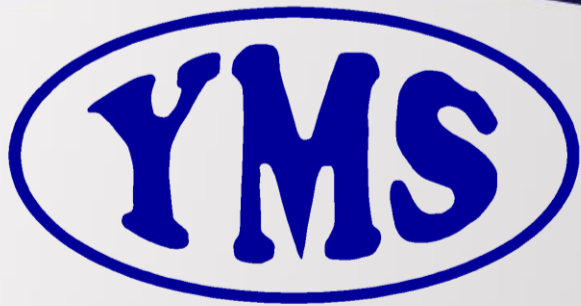

Yorke Maintenance Services

No : 558B ,Moragahahena road, Pitipana noth
Homagama

Tel No: 0112 086 212 , 071 489 2075

Email: ymsrilanka@gmail.com

About us

We are a leading provider of cooling tower solutions in Sri Lanka. Founded in 2007, drawing on over 30 years of experience in refrigeration and air conditioning maintenance, we identified a gap in the market for specialized cooling tower service, repair and. As a local company, we understand the challenges of relying on imported parts and the associated costs.

Our Mission

"To be the most sought-after Sri Lankan professional organization providing total cooling tower solutions meeting trade standards. To achieve this, we are committed to maximizing customer savings, minimizing reliance on foreign currency, and fostering opportunities for local manufacturers.

Our Vision

"To be leader in cooling tower manufacturer, cooling tower spare parts supplier and related service provider in Sri Lanka."

We envision ourselves as the leader in cooling tower manufacturing, spare parts supply, and related services in Sri Lanka. We aim to create a one-stop shop for all your cooling tower requirements, supporting local manufacturers and contributing to the Sri Lankan economy.

Our Services

- **Manufacturing of Common Cooling Tower Spare Parts:**
 - Sprinkler Heads
 - Fan Hubs & Blades
 - Infill Material
- **Hot-Dip Galvanized Metal Parts Fabrication**
 - Infill Rest
 - Tower Pillars
 - Fan Mounting Frame
 - Basin Supports
- **Custom Cooling Tower Spare Parts Manufacturing**
 - We can manufacture spare parts to your specific requirements.
- **Cooling Tower Renovation and Upgradation Services**
 - Extend the life and improve the performance of your existing cooling tower.
- **Cooling Tower Manufacturing**
 - We design and build cooling towers to meet your exact specifications.

Why Choose Us?

- **Local Expertise:** With extensive experience in the Sri Lankan market, we understand your specific needs and challenges.
- **Reduced Costs:** By offering locally manufactured parts, we help you save money on expensive imports.
- **Quality and Reliability:** We use high-quality materials and adhere to strict manufacturing standards to ensure the durability and performance of our products.
- **Customizable Solutions:** We can cater to your specific requirements, whether it's a custom spare part or a complete cooling tower system.
- **Comprehensive Services:** From spare parts to complete cooling tower solutions, we offer everything you need for your cooling tower maintenance and operation.

Material of YMS cooling tower

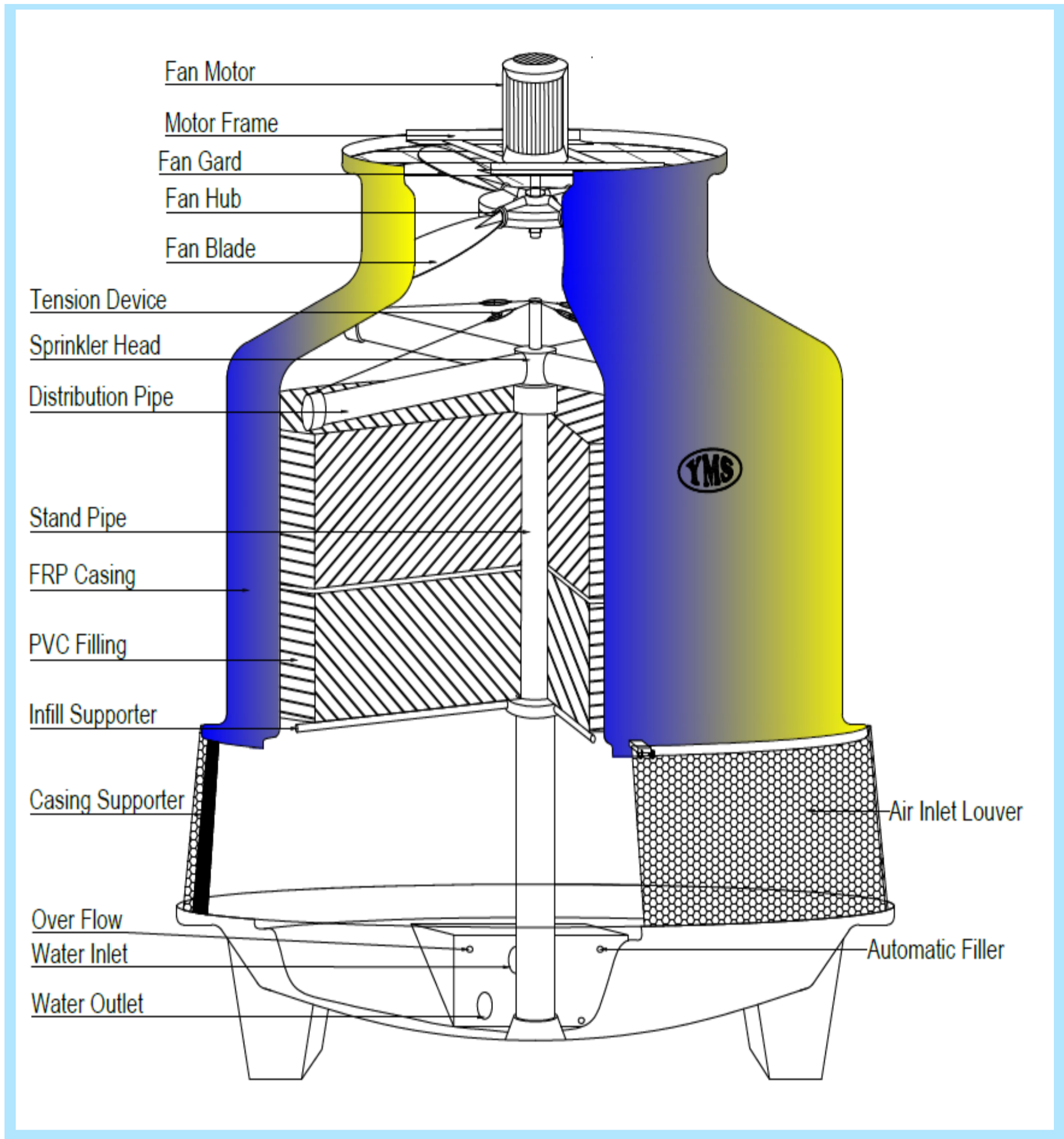

MODEL	8	10	15	20	25	30	40	50	60	80	100	125
MOTOR	380,415V, 50HZ/60HZ											
FAN DRIVE	DIRECT											
FAN BLADE	REINFORCED PLASTIC						ALUMINIUM ALLOY					
CASING	F.R.P											
WATER BASIN	F.R.P											
SPRINKLER HEAD	REINFORCED PLASTIC						ALUMINIUM ALLOY					
FILL	THERMOPRESS											
AIR MESH	P.V.C MESH											
LADDER	NOT FITTED						HOT DIP GALVANIZED STEEL					
TOWER SUPPORT	PLASTIC			HOT DIP GALVANIZED STEEL								

YMS cooling tower selection table

		Normal Temperature							
Wet bulb (C°)		27 C°		28 C°		29 C°		30 C°	
L/min	C°	37 C°	37.5 C°	37 C°	37.5 C°	37 C°	37.5 C°	38 C°	38.5 C°
	Model	32 C°	32 C°	32 C°	32 C°	32 C°	32 C°	33 C°	33 C°
YMS –8 Ton		104	95	88	80	70	66	76	70
YMS –10 Ton		130	120	100	95	88	82	95	88
YMS –15 Ton		195	180	152	148	133	123	142	133
YMS –20 Ton		260	240	220	200	177	165	190	177
YMS –25 Ton		325	300	275	255	220	210	240	220
YMS –30 Ton		390	360	330	305	270	250	290	266
YMS –40 Ton		520	480	440	415	375	355	395	375
YMS –50 Ton		650	600	550	530	470	440	500	470
YMS –60 Ton		780	720	660	615	560	520	590	560
YMS –80 Ton		1040	962	892	826	733	700	788	743
YMS –100 Ton		1300	1210	1120	1025	925	829	937	877
YMS –125 Ton		1625	1513	1398	1304	1152	1104	1237	1166
YMS –150 Ton		1950	1814	1680	1563	1391	1330	1495	1415

YMS- 8Ton -10 Ton cooling towers

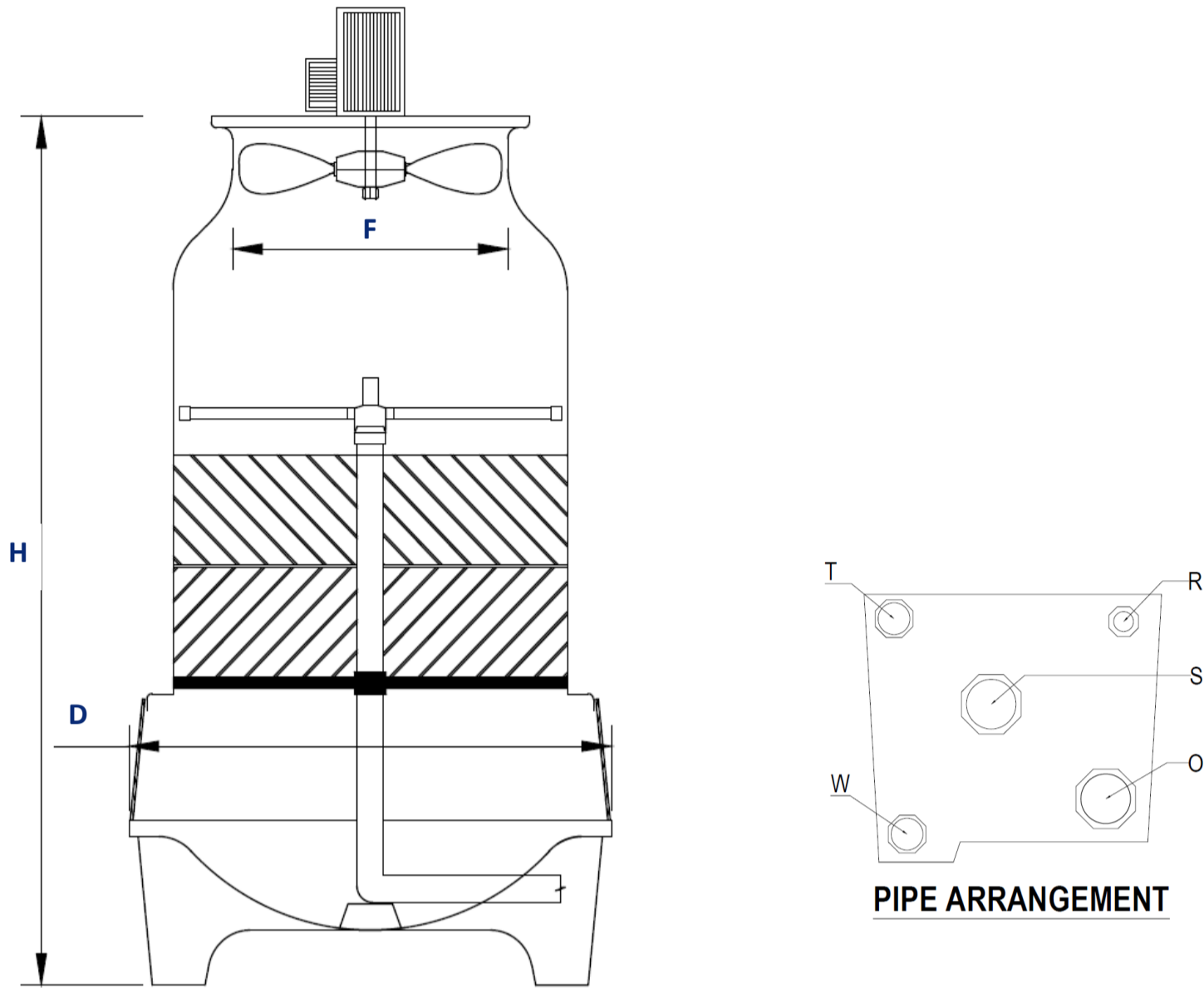

Tower Model	Dimension (mm)		Pipe Connection (mm)					Fan Motor Hp and Poles	Fan Dia (mm)	Nominal Water Flow (m ³ /Hr)
	H	D	S	O	T	W	R		F	
YMS-8 Ton	1580	920	50	50	32	32	20	0.5Hp - 6pole	490	6.2
YMS-10 Ton	1580	920	50	50	32	32	20	0.5Hp - 6pole	615	7.8

Foundation details for 8 Ton & 10 Ton towers

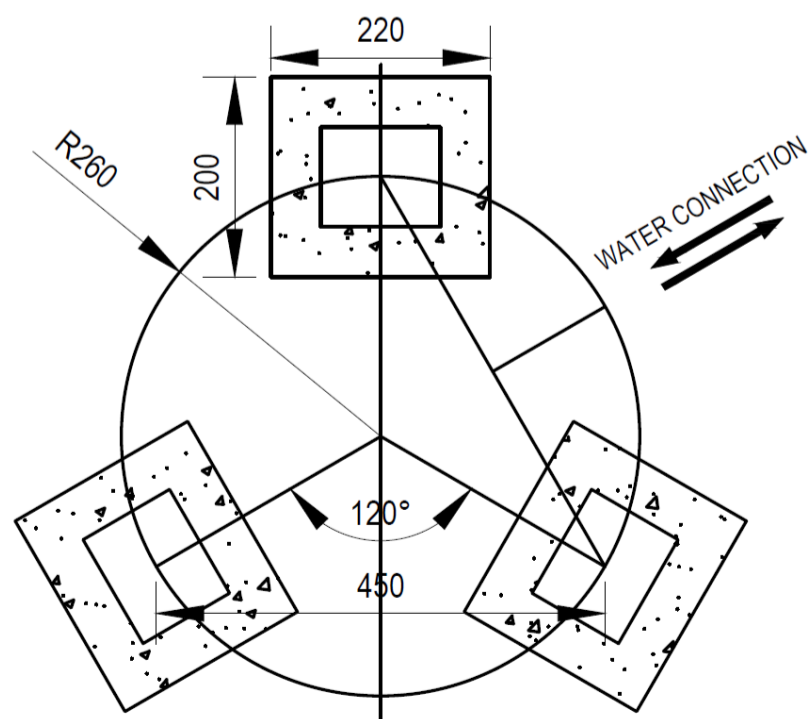

YMS- 15Ton – 25 Ton cooling towers

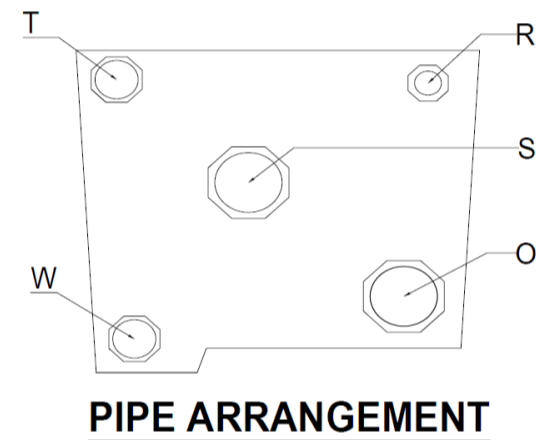
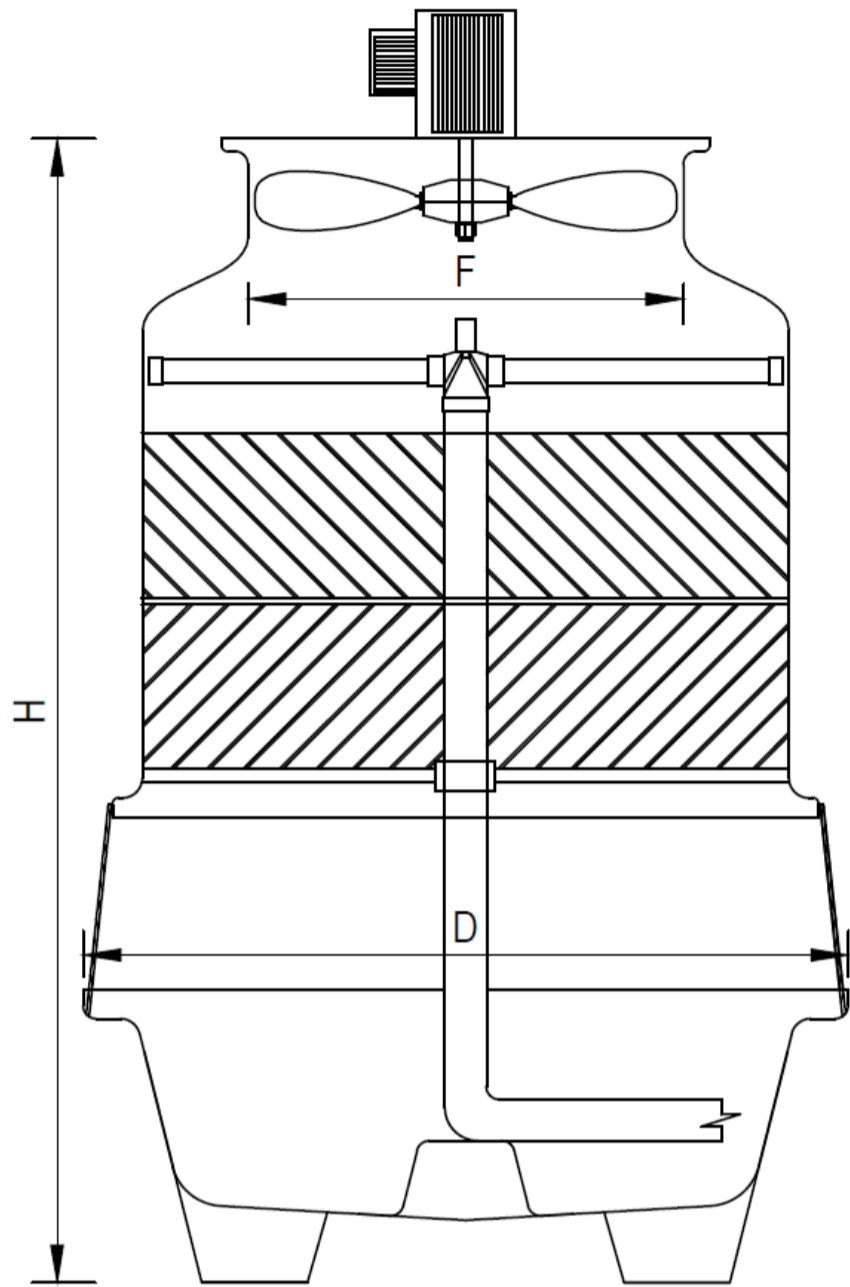

Tower Model	Dimension (mm)		Pipe Connection (mm)					Fan Motor Hp and Poles	Fan Dia (F) (mm)	Nominal Water Flow (m3/Hr)
	H	D	S	O	T	W	R			
YMS-15 Ton	1565	1160	63	63	32	32	20	1 Hp-6 poles	635	11.7
YMS-20 Ton	1735	1160	63	63	32	32	20	1 Hp-6 poles	635	15.6
YMS-25 Ton	1835	1160	63	63	32	32	20	1 Hp-6 poles	740	19.6

Foundation details for 15Ton,20Ton & 25 Ton Colling towers

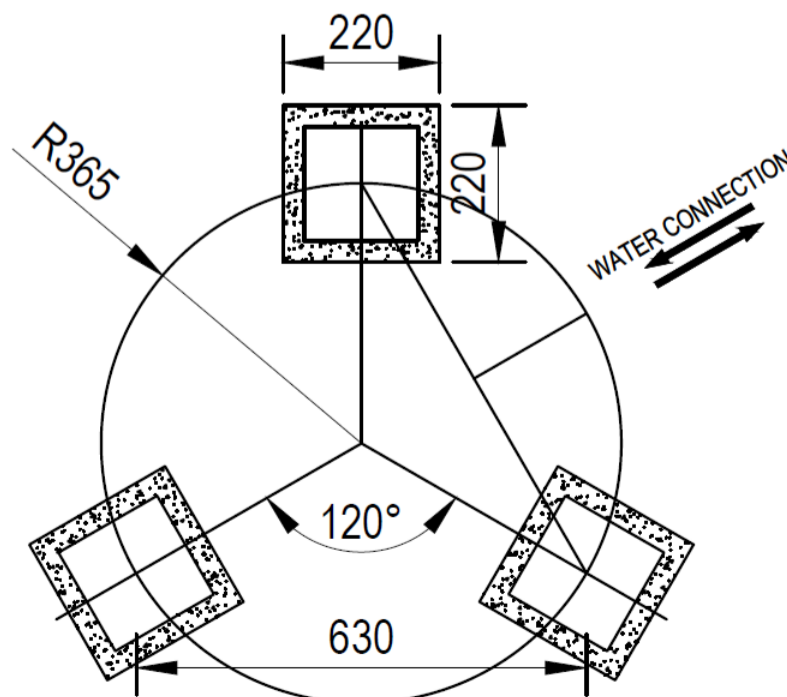

YMS-30 Ton cooling tower

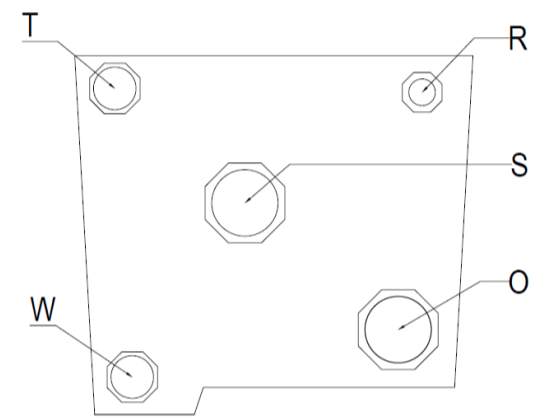
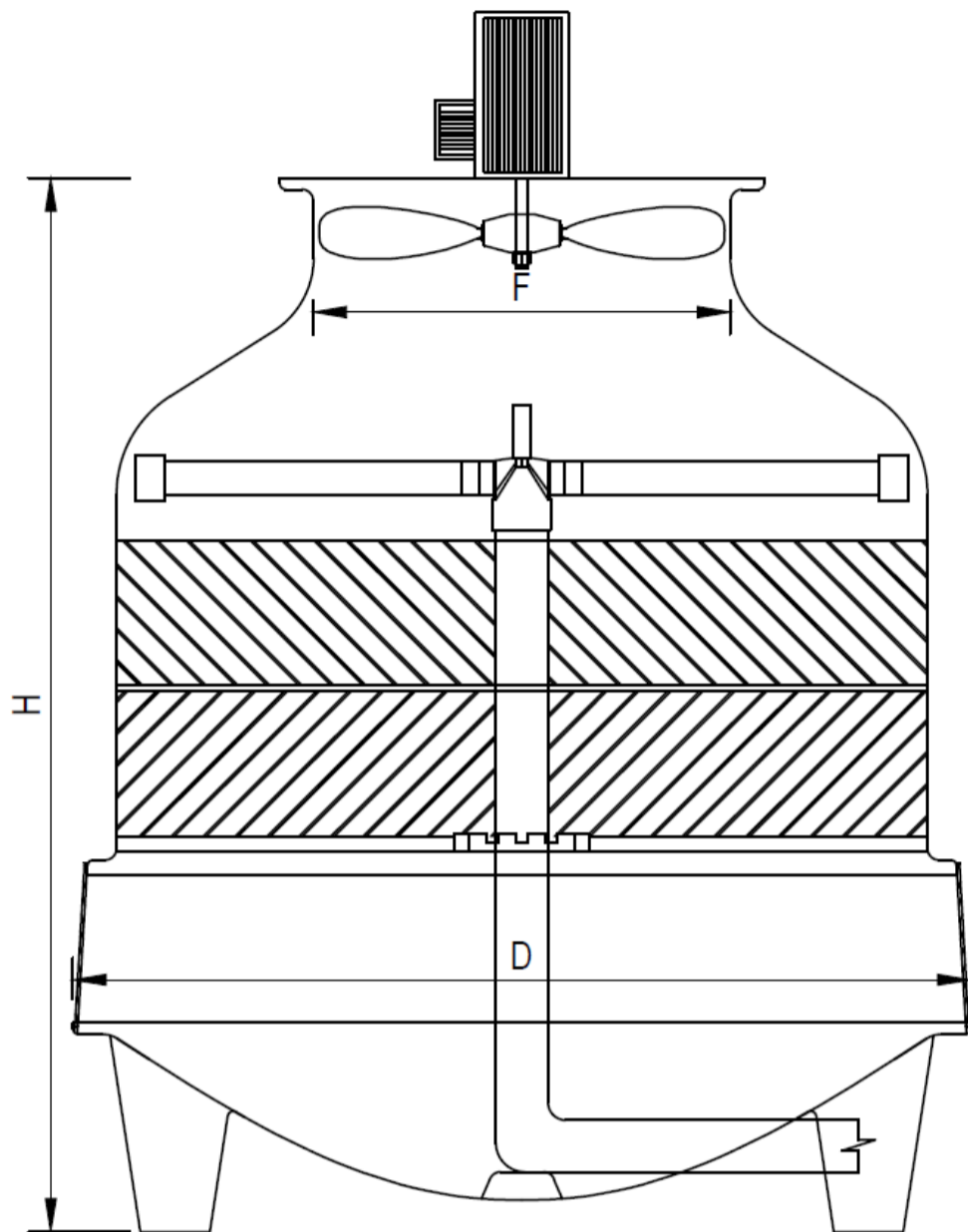

PIPE ARRANGEMENT

Tower Model	Dimension (mm)		Pipe Connection (mm)					Fan Motor Hp and Poles	Fan Dia (mm)	Nominal Water Flow (m ³ /Hr)
	H	D	S	O	T	W	R			
YMS-30 Ton	1815	1550	90	90	50	32	20	1.5Hp-6Poles	685	23.4

Foundation details for 30 Ton cooling tower

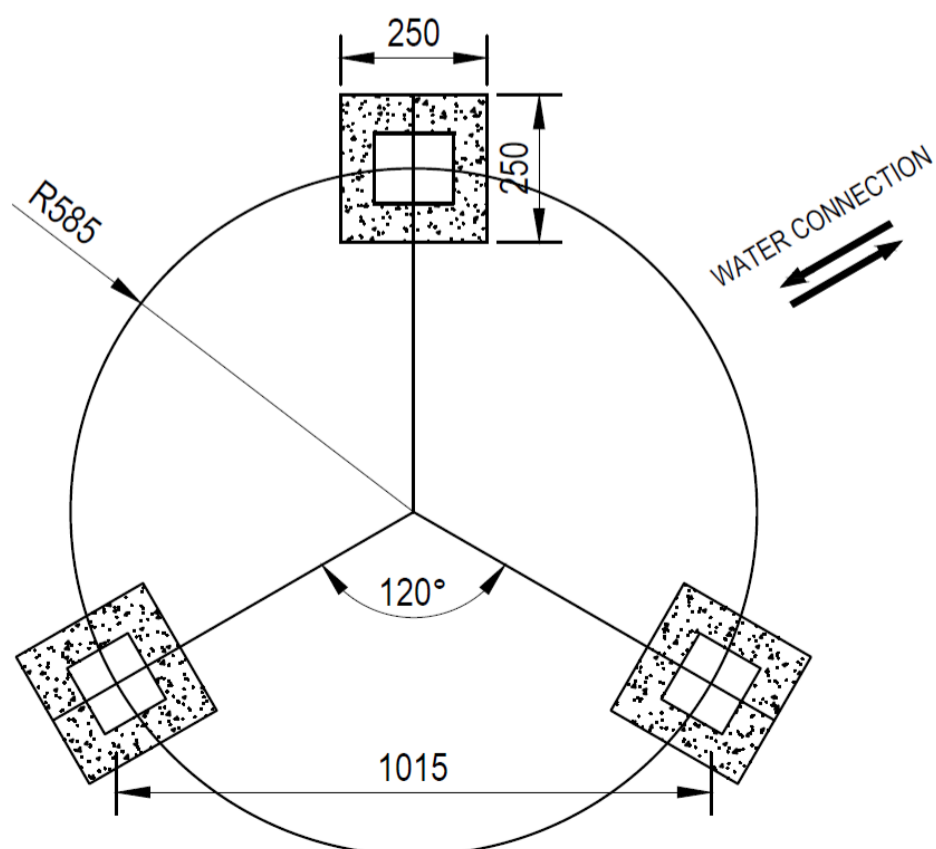

YMS- 40Ton -80 Ton cooling towers

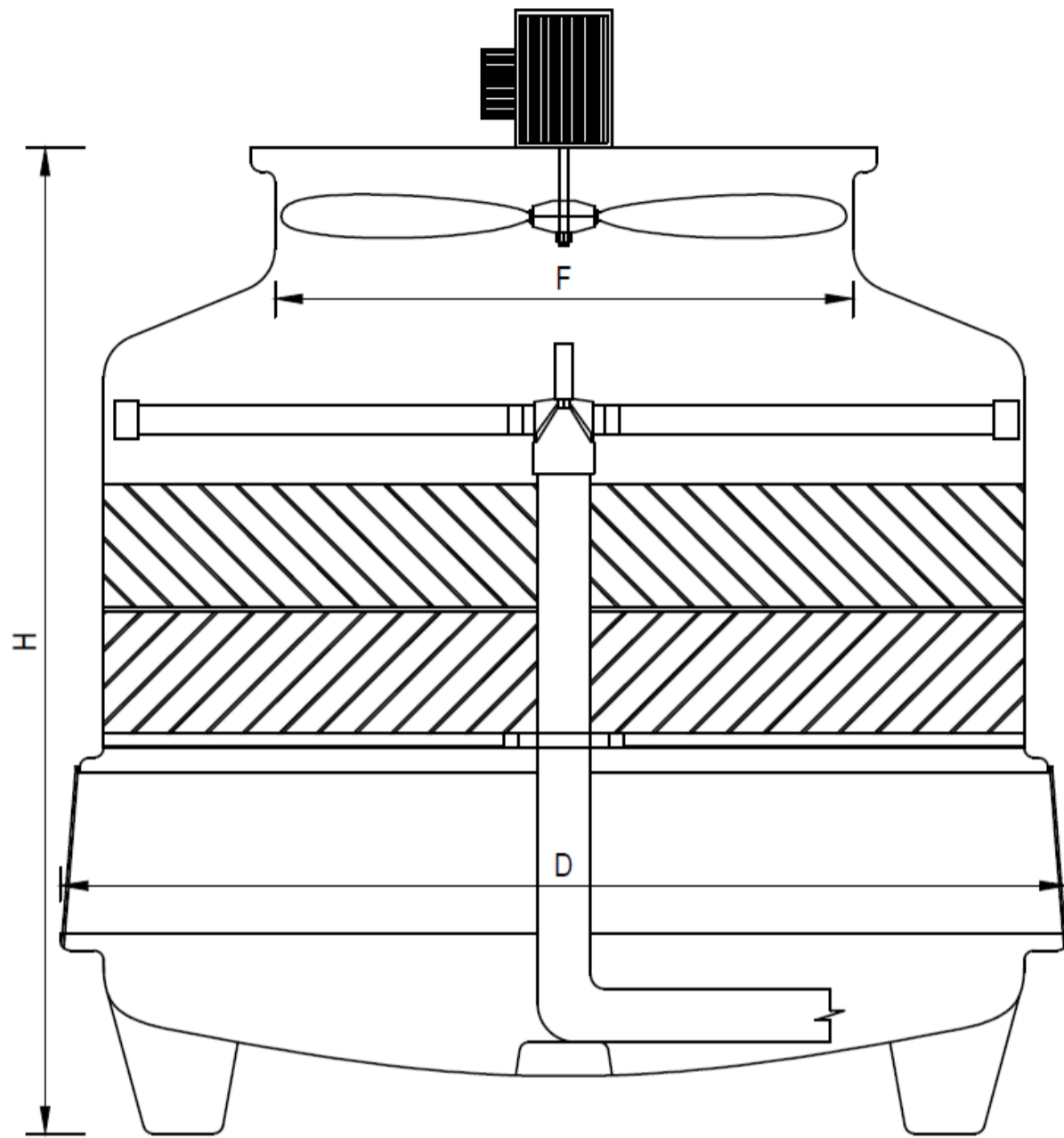

Tower Model	Dimension (mm)		Pipe Connection (mm)					Fan Motor Hp and Poles	Fan Dia (mm)	Nominal Water Flow (m3/Hr)
	H	D	a	b	c	d	e			
YMS-40 Ton	1805	1650	90	90	32	32	20	1.5Hp -6 pols	930	31.2
YMS-50 Ton	1910	1990	90	90	40	40	20	2.0 Hp -6 pols	1145	39
YMS-60 Ton	2045	2090	110	110	40	40	25	2.0 Hp -6 pols	1180	46.9
YMS-80 Ton	2300	2090	110	110	40	40	25	2.0 Hp -6 pols	1180	62.4

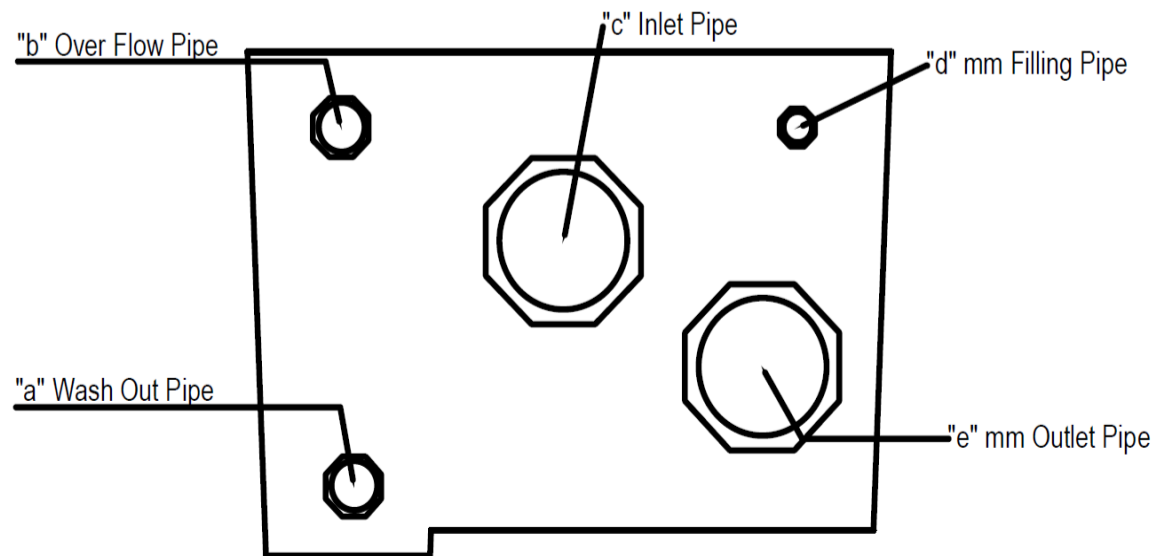

PIPE ARRANGEMENT

Foundation details for YMS- 40 Ton,50 Ton, 60Ton & 80 Ton Colling towers

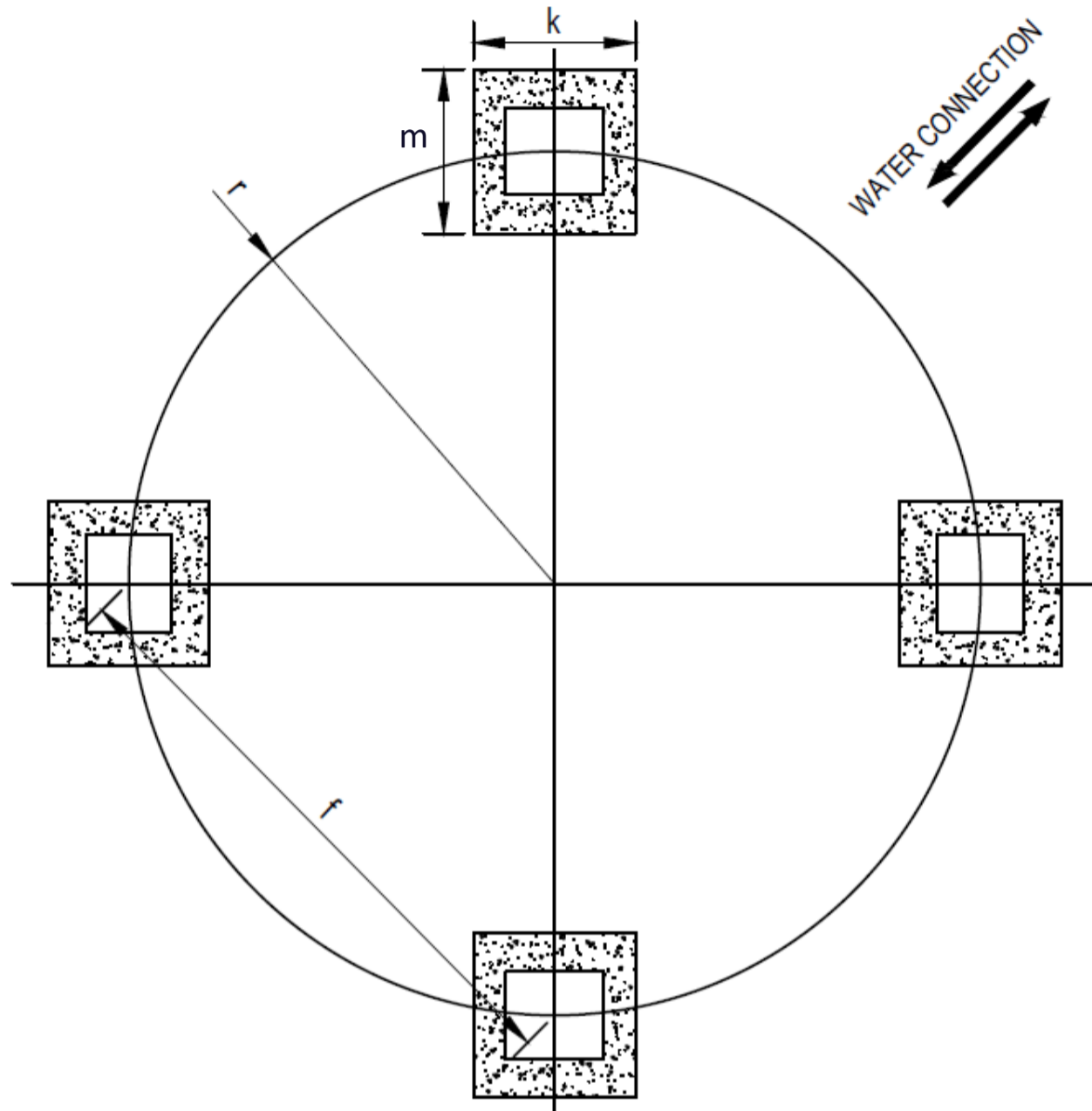

FOUNDATION DETAILS

Tower Model	Foundation details			
	f	r	m	k
YMS – 40 Ton	835mm	590mm	250mm	250mm
YMS – 50 Ton	1175mm	830mm	300mm	300mm
YMS – 60 Ton	1115mm	790mm	300mm	300mm
YMS – 80 Ton	1115mm	790mm	300mm	300mm

YMS- 100Ton -125 Ton cooling towers

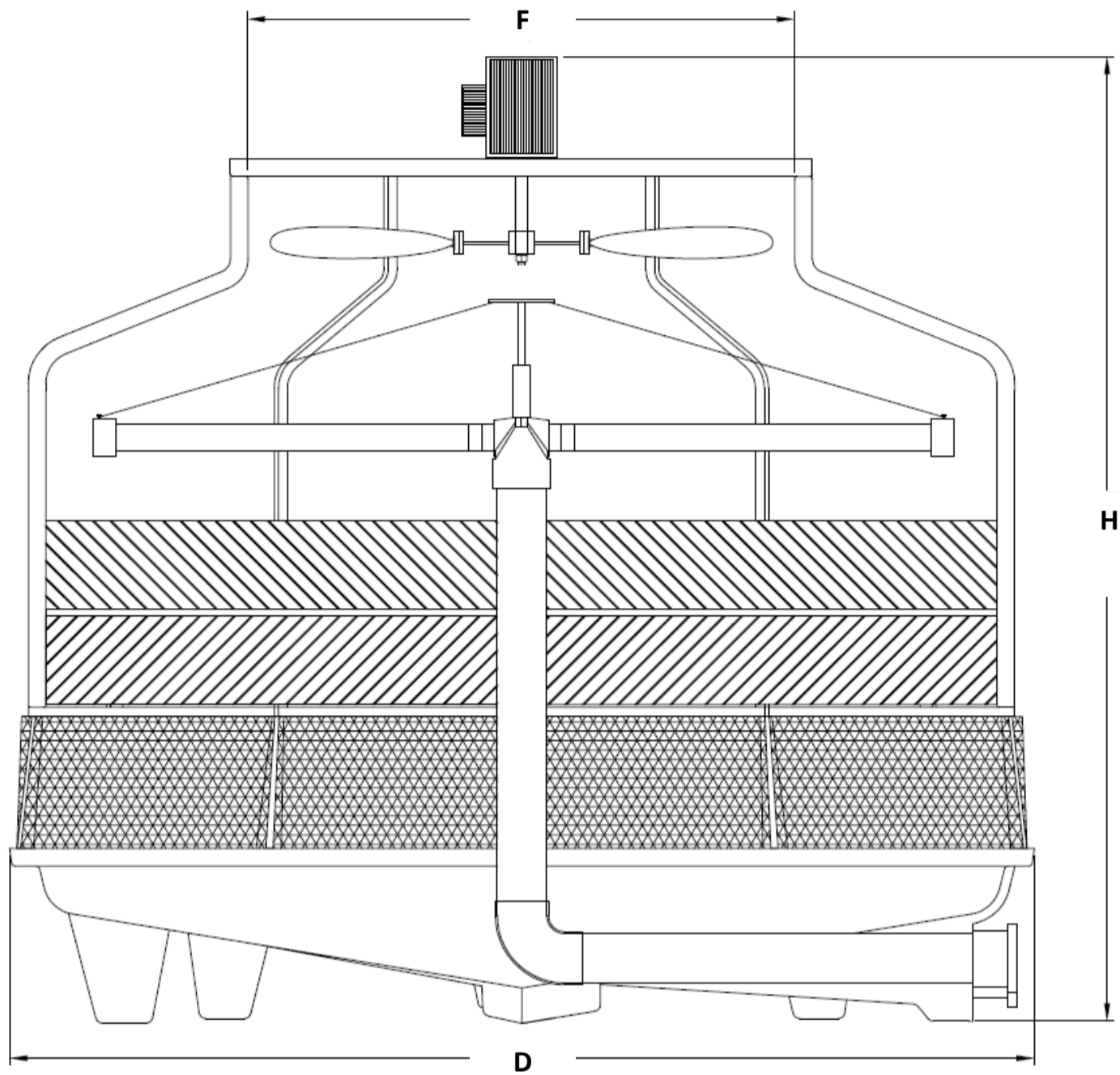

Tower Model	Dimension (mm)			Pipe Connection (mm)						Fan Motor Power and Poles	Fan Dia (mm)	Nominal Water Flow (m3/Hr)
	H	F	D	I	O	Dr	Ba	Q	e			
YMS-100 Ton	2732mm	1550mm	2900mm	140mm	140mm	50mm	25mm	25mm	25mm	3Hp -8 pols	1450mm	78
YMS-125 Ton	2732mm	1550mm	2900mm	140mm	140mm	50mm	25mm	25mm	25mm	3Hp -8 pols	1450mm	97.5

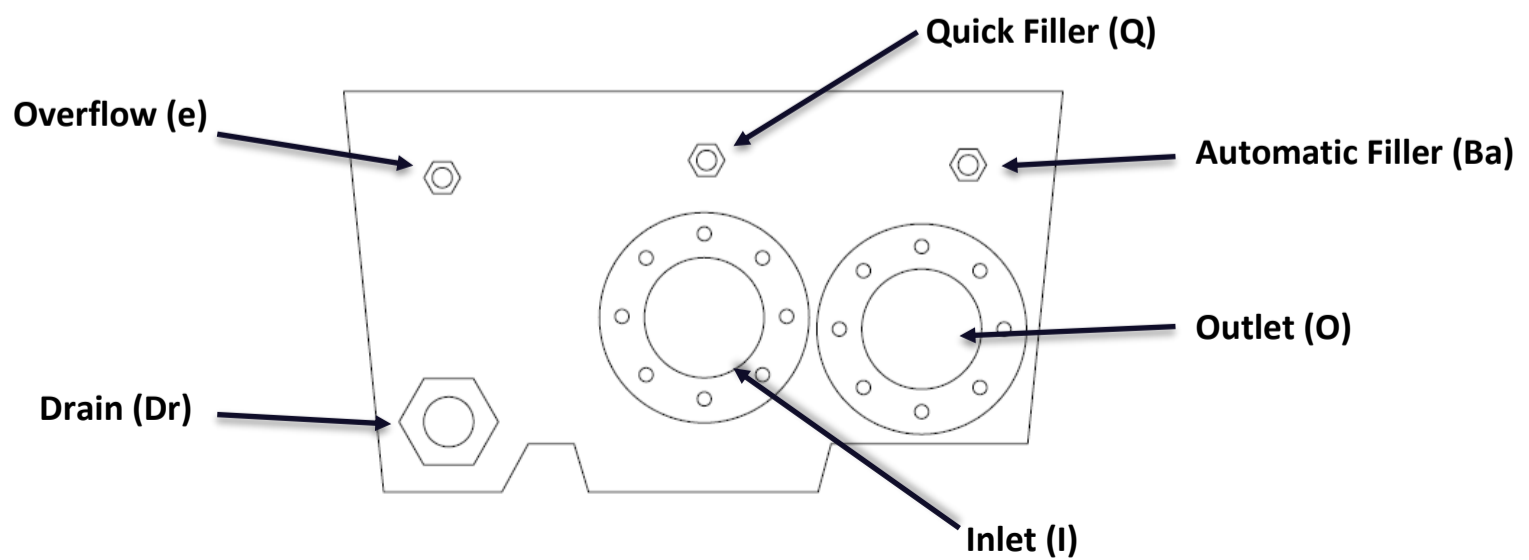

Foundation details for YMS- 100 Ton & 125 Ton Colling towers

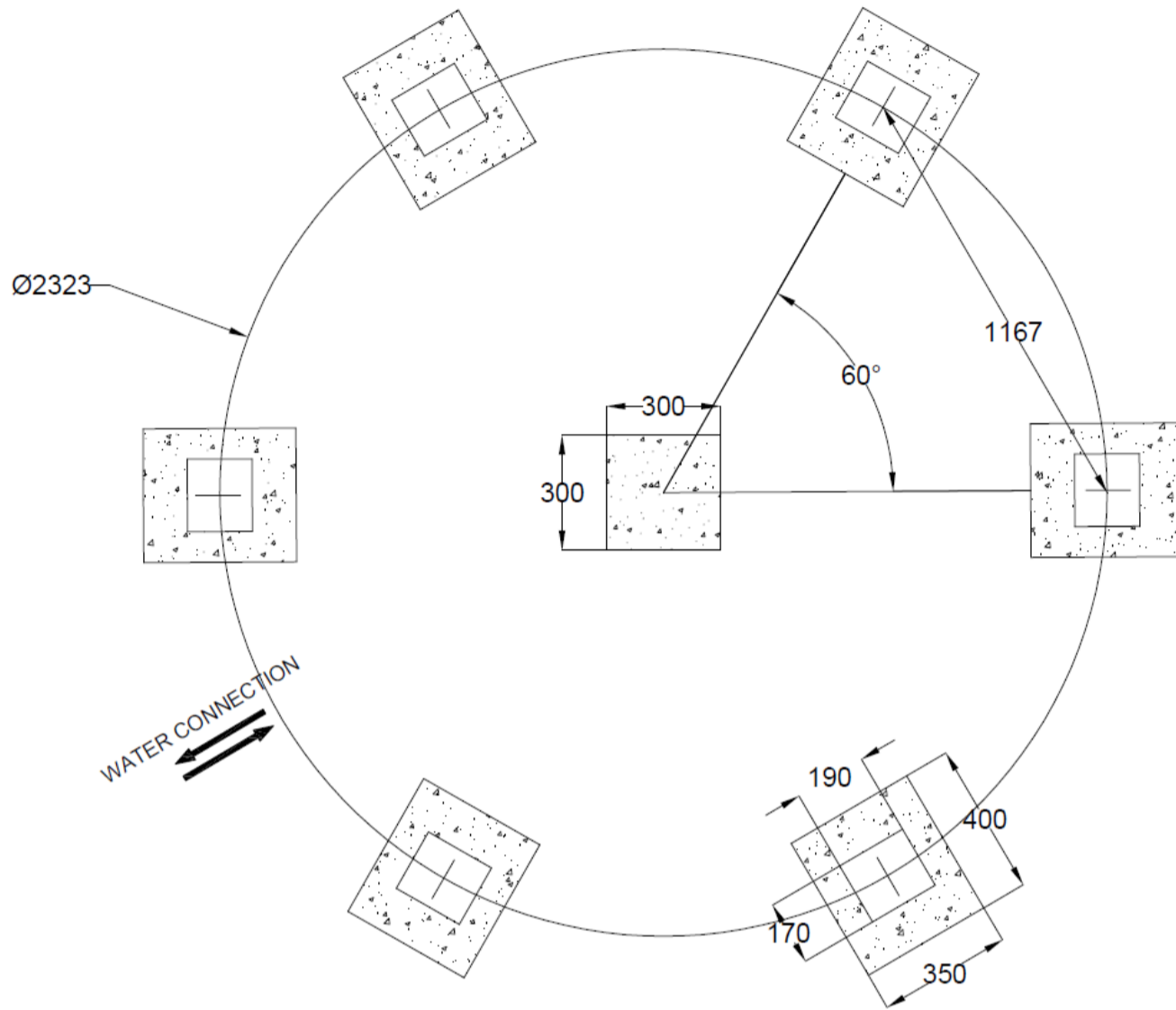

FOUNDATION DETAILS

JOB REFERENCES

❖ A/C COMPANYS

- ABANS ENGINEERING (PVT) LTD
- BUILD MECH SERVICES (PVT) LTD
- CIVIMECH (PVT) LTD
- METROPOLITAN TECHNOLOGIES (PVT) LTD
- C D ENGINEERING (PVT) LTD
- K & A ENGINEERS (PVT) LTD
- G T A REFRIGERATION (PVT) LTD
- MULTY AIR TECHNOLOGIES (PVT) LTD
- QUALITAIR AIR CONDITIONING (PVT)LTD
- SUNCO ENGINEERING (PVT)LTD
- MEP ENGINEERING AND TRADING COMPANY (PVT)LTD
- J I AIR CONDITIONING COMPANY
- AIR CONTROL TECHNIQUES.

❖ GROUP OF COMPANYS

- HAYLEYS GROUP
- CAPITOL MAHARAJA GROUP
- CARGILL'S FOODS COMPANY (PVT) LTD
- OREL COPERATION (PVT)LTD
- WICKRAMARATHNA GROUP
- NAWALA CUSHION WORKS (PVT) LTD
- NAWALOKA HOSPITAL PLC
- SINGHE HOSPITALS PLC
- SETHMA PRIVATE HOSPITAL
- ASSOCIATED BATTERY MANUFACTURERS (CEYLON) LIMITED
- BRANDIX APPAREL SOLUTIONS LIMITED
- PELAWATTHA DAIRY INDUSTRIES LTD
- SILVER MILL (PVT) LTD

❖ HOTELS

- AITKEN SPENCE HOTEL HOLDINGS PLC (HERITANCE AHUNGALLA)
- TRANS AISA HOTELS PLC (CINNAMON LAKE)
- JETWING HOTEL COMPANY (BENTHOTA BEACH HOTEL)
- GALADARI HOTEL
- TAJ SAMUDRA HOTEL
- BERUWALA HOLIDAY RESORT
- PEGASUS REEF HOTEL

❖ COIR PRODUCT COMPANIES

- BOTANI COIR
- TROPY COIR LANKA
- CEY COIR SUBSTRATES (PVT) LTD
- WON COIR INTERNATIONAL (PVT) LTD